

### ABSTRACT

Direct-sequence code-division multiple access (DS-CDMA) is a popular wireless technology. In DS-CDMA communications, all of the users' signals overlap in time and frequency and cause mutual interference. The conventional DS-CDMA detector follows a single-user detection strategy in which each user is detected separately without regard for the other users. A better strategy is multi-user detection, where information about multiple users is used to improve detection of each individual user. This article describes a number of important multi-user DS-CDMA detectors that have been proposed.

---

# Multi-User Detection for DS-CDMA Communications

Shimon Moshavi, Bellcore

**T**he year is 2010, and the world has gone wireless. The wireless personal communicator is as common as the wireline telephone used to be, and it provides reliable and affordable communication, anywhere and anytime: in the car, restaurant, park, home, or office, or on the slopes of the Swiss Alps. Portable computers provide a vast array of integrated wireless services, such as voice, data, and video communications, movies and television programs on demand, and unlimited access to the treasures of cyberspace.

To bring this vision to fruition, major improvements in the current state of wireless technology are necessary. One type of wireless technology which has become very popular over the last few years is direct-sequence code-division multiple access (DS-CDMA). In this article we review multi-user detection, an area of research with the potential to significantly improve DS-CDMA communications.

Code-division multiple access (CDMA) is one of several methods of multiplexing wireless users. In CDMA, users are multiplexed by distinct codes rather than by orthogonal frequency bands, as in frequency-division multiple access (FDMA), or by orthogonal time slots, as in time-division multiple access (TDMA). In CDMA, all users can transmit at the same time. Also, each is allocated the entire available frequency spectrum for transmission; hence, CDMA is also known as spread-spectrum multiple access (SSMA), or simply spread-spectrum communications.

Direct-sequence CDMA is the most popular of CDMA techniques. The DS-CDMA transmitter multiplies each user's signal by a distinct code waveform. The detector receives a signal composed of the sum of all users' signals, which overlap in time and frequency. In a conventional DS-CDMA system, a particular user's signal is detected by correlating the entire received signal with that user's code waveform.

There has been substantial interest in DS-CDMA technology in recent years because of its many attractive properties for the wireless medium [1-4].<sup>1</sup> While DS-CDMA systems are only now beginning to be commercially deployed, these properties have led to expectations of large capacity increases over TDMA and FDMA systems. Air interface standards based on DS-CDMA, IS-95, and IS-665 [5] have been defined,

and a strong commercial effort is currently underway to deploy cellular systems that use them. (See the article in this issue describing IS-665.)

Multiple access interference (MAI) is a factor which limits the capacity and performance of DS-CDMA systems. MAI refers to the interference between direct-sequence users. This interference is the result of the random time offsets between signals, which make it impossible to design the code waveforms to be completely orthogonal. While the MAI caused by any one user is generally small, as the number of interferers or their power increases, MAI becomes substantial.<sup>2</sup> The conventional detector does not take into account the existence of MAI. It follows a single-user detection strategy in which each user is detected separately without regard for other users.

Because of the interference among users, however, a better detection strategy is one of multi-user detection (also referred to as joint detection or interference cancellation). Here, information about multiple users is used jointly to better detect each individual user. The utilization of multi-user detection algorithms has the potential to provide significant additional benefits for DS-CDMA systems.

The next section contains a description of conventional DS-CDMA detection. In the third section we discuss multi-user detection, and we review the optimal multi-user sequence detector. We then review the two main classes of suboptimal detectors that have been proposed: linear multi-user detectors and subtractive interference cancellation multi-user detectors. This is followed by a summary and concluding remarks.

## CONVENTIONAL DETECTION

**I**n this section we take a more detailed look at the conventional detector and the effect of multiple access interference; but first we must define the mathematical system model.

### RECEIVED SIGNAL MODEL

We begin with a mathematical description of a synchronous DS-CDMA channel. In a synchronous channel all bits of all users are aligned in time. In practical DS-CDMA applications, however, the channel is generally asynchronous (i.e., signals

are randomly delayed — offset — from one another). The asynchronous channel is described in the next section.

To simplify the discussion, we make the assumption that all carrier phases are equal to zero. This enables us to use baseband notation while working only with real signals. To further simplify matters, we also assume that each transmitted signal arrives at the receiver over a single path (no multipath), and that the data modulation is binary phase-shift keying (BPSK [8]).

Assuming there are  $K$  direct-sequence users in a synchronous single-path BPSK real channel, the baseband received signal can be expressed as

$$r(t) = \sum_{k=1}^K A_k(t)g_k(t)d_k(t) + n(t) \quad (1)$$

where  $A_k(t)$ ,  $g_k(t)$ , and  $d_k(t)$  are the amplitude, signature code waveform, and modulation of the  $k$ th user, respectively, and  $n(t)$  is additive white Gaussian noise (AWGN), with a two-sided power spectral density of  $N_0/2$  W/Hz. The power of the  $k$ th signal is equal to the square of its amplitude, which is assumed to be constant over a bit interval. The modulation consists of rectangular pulses of duration  $T_b$  (bit interval), which take on  $d_k = \pm 1$  values corresponding to the transmitted data. We assume a total of  $N$  transmitted bits. The code waveform consists of rectangular pulses of duration  $T_c$  (“chip” interval), which pseudorandomly take on  $\pm 1$  values, corresponding to some binary “pseudo-noise” (PN) code sequence [5, 8].

The rate of the code waveform,  $f_c = 1/T_c$  (chip rate), is much greater than the bit rate,  $f_b = 1/T_b$ . Thus, multiplying the BPSK signal at the transmitter by  $g(t)$  has the effect of spreading it out in frequency by a factor of  $f_c/f_b$ , (hence, the codes are sometimes referred to as “the spreading codes.”) The frequency spread factor of a direct-sequence system is referred to as the processing gain, PG. Hence, for the model of Eq. (1) there are PG chips per bit.

### THE CONVENTIONAL DETECTOR

The conventional detector for the received signal described in Eq. (1) is a bank of  $K$  correlators, as shown in Fig. 1. Here, each code waveform is regenerated and correlated with the received signal in a separate detector branch. The correlation detector can be equivalently implemented through what is known as matched filtering [8];<sup>3</sup> thus, the conventional detector is often referred to as the matched filter detector. The outputs of the correlators (or matched filters) are sampled at the bit times, which yields “soft” estimates of the transmitted data. The final  $\pm 1$  “hard” data decisions are made according to the signs of the soft estimates.

It is clear from Fig. 1 that the conventional detector follows a single-user detector strategy; each branch detects one user without regard to the existence of the other users. Thus, there is no sharing of multiuser information or joint signal processing (i.e., multi-user detection).

The success of this detector depends on the properties of the correlations between codes. We require the correlations between the same code waveforms (i.e., the autocorrelations) to be much larger than the correlations between different codes (i.e., the cross-correlations). The correlation value is defined as

$$\rho_{i,k} = \frac{1}{T_b} \int_{T_b} g_i(t)g_k(t)dt \quad (2)$$

Here, if  $i = k$ ,  $\rho_{i,k} = 1$ , (i.e., the integrand must equal one since  $g_i(t) = \pm 1$ ), and if  $i \neq k$ ,  $0 \leq \rho_{i,k} < 1$ . The output of the  $k$ th user’s correlator for a particular bit interval is

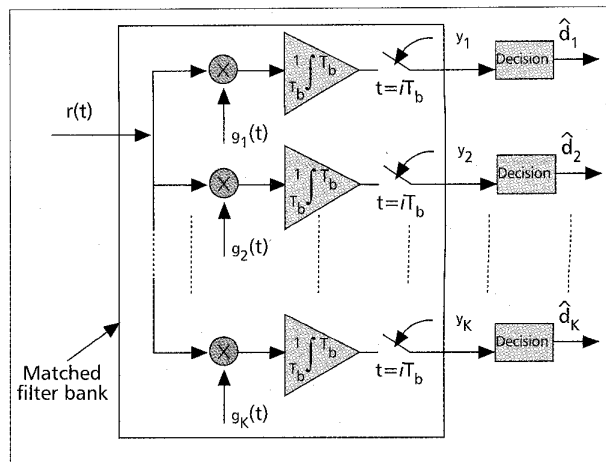

■ Figure 1. The conventional DS-CDMA detector: a bank of correlators (matched filters).

$$\begin{aligned} y_k &= \frac{1}{T_b} \int_{T_b} r(t)g_k(t)dt \\ &= A_k d_k + \sum_{\substack{i=1 \\ i \neq k}}^K \rho_{i,k} A_i d_i + \frac{1}{T_b} \int_{T_b} n(t)g_k(t)dt \\ &= A_k d_k + MAI_k + z_k \end{aligned} \quad (3)$$

In other words, correlation with the  $k$ th user itself gives rise to the recovered data term, correlation with all the other users gives rise to multiple access interference (MAI), and correlation with the thermal noise yields the noise term  $z_k$ . Since the codes are generally designed to have very low cross-correlations relative to autocorrelations (i.e.,  $\rho_{i,k} \ll 1$ ), the interfering effect on user  $k$  of the other direct-sequence users is greatly reduced.<sup>4,5</sup>

Nevertheless, the existence of MAI has a significant impact on the capacity and performance of the conventional direct-sequence system. As the number of interfering users increases, the amount of MAI increases. In addition, the presence of strong (large-amplitude) users exacerbates the MAI of the weaker users, as can be seen by Eq. (3). Thus, the overall effect of MAI on system performance is even more pronounced if the users’ signals arrive at the receiver at different powers: weaker users may be overwhelmed by stronger users. Such a situation arises when the transmitters have different geographical locations relative to the receiver, because the signals of the closer transmitting users undergo less amplitude attenuation than the signals of users that are further away. This is known as the near-far problem. (Note that this problem also arises due to fading.)

An analogy which helps to illustrate the effect of MAI is as follows. Consider that you are at a party where every conversation takes place in a different language. In general, your ear is reasonably good at picking out your own language and tuning out the other conversations. However, as the number of simultaneous conversations in the room increases, it becomes harder and harder to continue your own conversation. Similar difficulties arise if some of the other conversations get closer or louder, or if the person you are talking to moves further away or begins to whisper (the near-far effect).

### MITIGATING THE EFFECT OF MAI

Research efforts directed at mitigating the effect of MAI on the conventional detector have focused on several areas.

**Code Waveform Design** — This approach is aimed at the design of spreading codes with good cross-correlation properties. Ideally, if the codes were all orthogonal, then  $\rho_{i,k} = 0$ , and

there would be no MAI term. However, since in practice most channels contain some degree of asynchronism, it is not possible to design codes that maintain orthogonality over all possible delays. So instead we look for codes that are nearly orthogonal, that is, have as low cross-correlation as possible (e.g., [11, 12]).

**Power Control** — The use of power control ensures that all users arrive at about the same power (amplitude), and therefore no user is unfairly disadvantaged relative to the others (e.g. [13]). In the IS-95 standard, the mobiles adjust their power through two methods. One method is for the mobiles to adjust their transmitted power to be inversely proportional to the power level it receives from the base station (open loop power control). The other method is for the base station to send power control instructions to the mobiles based on the power level it receives from the mobiles (closed loop power control) [5]. Power control is currently considered indispensable for a successful DS-CDMA system.

**FEC Codes** — The design of more powerful forward error correction (FEC) codes allows acceptable error rate performance at lower signal-to-interference ratio levels. This obviously has broad application, and provides benefits to more than just CDMA systems.

**Sectored/Adaptive Antennas** — Here, directed antennas are used that focus reception over a narrow desired angle range. Therefore, the desired signal and some fraction of the MAI are enhanced (through the antenna gain), while the interfering signals that arrive from the remaining angles are attenuated. The direction of the antenna can be fixed, as is the case for sectored antennas, or adjusted dynamically. In the latter case, adaptive signal processing is used to focus the antenna in the direction corresponding to a particular desired user(s). Applications for these techniques also extend well beyond CDMA. An overview of the work in this area can be found in [14].

## MULTI-USER DETECTION

There has been great interest in improving DS-CDMA detection through the use of multi-user detectors. In multi-user detection, code and timing (and possibly amplitude and phase) information of multiple users are jointly used to better detect each individual user. The important assumption is that the codes of the multiple users are known to the receiver *a priori*.<sup>6</sup>

Verdú's seminal work [31], published in 1986, proposed and analyzed the optimal multiuser detector, or the maximum likelihood sequence detector (described later in this section). Unfortunately, this detector is much too complex for practical DS-CDMA systems. Therefore, over the last decade or so, most of the research has focused on finding suboptimal multi-user detector solutions which are more feasible to implement.

Most of the proposed detectors can be classified in one of two categories: linear multi-user detectors and subtractive interference cancellation detectors. In linear multi-user detection, a linear mapping (transformation) is applied to the soft outputs of the conventional detector to produce a new set of outputs, which hopefully provide better performance. In subtractive interference cancellation detection, estimates of the interference are generated and subtracted out. We discuss several important detectors in each category in the next two sections.

There are other proposed detectors, as well as variations of each detector, that are not covered here. There is also a large and growing literature dealing with extensions of the various

multi-user algorithms to realistic environments.<sup>7-9</sup> The interested reader can find additional references and discussion in the survey articles [16-18].

It is interesting to note that there is a strong parallel between the problem of MAI and that of intersymbol interference (ISI). This point is made in [31], where the asynchronous  $K$ -user channel is identified with the single-user ISI channel with memory  $K - 1$ . The mathematical and conceptual similarity of the two problems is evident if one thinks of the  $K - 1$  overlapping ISI symbols as separate users. Therefore, a number of multi-user detectors have equalizer counterparts, such as the maximum-likelihood, zero-forcing, minimum mean-squared error, and decision-feedback equalizers [8]. We will point out these similarities as we go along.

### LIMITATIONS AND POTENTIAL BENEFITS

Before discussing the details of multi-user detection, it is important to examine some of the limitations that exist and potential benefits available. We focus on the cellular environment, although the ideas extend to other wireless applications.

In a cellular environment, there are two channels in a given coverage region: a central station, called a base station, transmits to mobiles (downlink), and the mobiles transmit to the base station (uplink). The coverage region associated with one base station is referred to as a cell. Generally, the uplink and the downlink utilize different frequency bands. There are two main limitations on the benefits of multiuser detection for the cellular environment:

**Existence of Other-Cell MAI** — In cellular DS-CDMA systems, the same uplink/ downlink pair of frequency bands are reused for each cell. Thus, a signal transmitted in one cell may cause interference in neighboring cells. If this interference is not included in the multi-user detection algorithm, the potential gain is significantly reduced. (A similar effect occurs from uncaptured multipath signals [1].) An upper bound on the capacity increase is easily derived by comparing the total interference for systems with and without multi-user detection. If we neglect background noise, the total interference in a system without multi-user detection is  $I = I_{\text{MAI}} + fI_{\text{MAI}}$ , where  $I_{\text{MAI}}$  is MAI due to same-cell users, and  $f$  is the ratio of other-cell MAI to same-cell MAI (also referred to as the *spillover ratio*). For an ideal system where all same-cell MAI is eliminated, we are still left with interference  $I = fI_{\text{MAI}}$ . Since the number of users is roughly proportional to the interference [3], the maximum capacity gain factor would be  $(1 + f)/f$  [1]. A typical value for  $f$  in cellular systems is 0.55 [1]; this translates to a maximum capacity gain factor of 2.8.

**Difficulty in Implementing Multi-User Detection on the Downlink** — Because issues of cost, size, and weight are much larger concerns for the mobiles than for the base station, it is not currently practical to include multi-user detection in mobiles. Instead, it has primarily been considered for use at the base station (for uplink reception of mobiles), where detection of multiple users is required in any case. However, improving the capacity of the uplink past that of the downlink does not improve the overall capacity of the system [17].

Despite these limitations, the use of multi-user detectors offers substantial potential benefits:

### Significant Improvement in Capacity

- Although other-cell MAI causes the capacity improvement for the cellular environment to be bounded, the improvement is still significant.
- The bound can be improved by including signals from the

- surrounding cells in the multi-user detection algorithm.<sup>10</sup>
- There are other applications, such as satellite communications, where the spillover ratio is much less than that of cellular communications.
  - Although multi-user detection is not currently practical for the downlink, DS-CDMA systems are generally considered to be uplink limited [3]. In addition, with improvements in technology, techniques for improving downlink performance may become more practical (e.g., see Endnote 6).

**More Efficient Uplink Spectrum Utilization** — The improvement in the uplink allows mobiles to operate at a lower processing gain [15]. This leads to a smaller chunk of bandwidth required for the uplink; the extra bandwidth could then be used to improve the downlink capacity. Alternatively, for the same bandwidth the uplink could support higher data rates.

**Reduced Precision Requirements for Power Control** — Since the impact of MAI and the near-far effect is much reduced, the need for all users to arrive at the receiver at exactly the same power is reduced; thus, less precision is needed in controlling the transmitted power of the mobiles. Therefore, the additional complexity at the base station required for multi-user detection may allow reduced complexity at the mobiles [15].

**More Efficient Power Utilization** — The reduction of interference on the uplink may translate to some reduction in the required transmit power of the mobiles [15]. Alternatively, the same transmit power may be used to extend the size of the coverage region.

#### MATRIX-VECTOR NOTATION

In discussing multi-user detection, it is convenient to introduce a matrix-vector system model to describe the output of the conventional detector. We begin with a simple example to help illustrate our discussion: a three user synchronous system. From Eq. (3), the output for each of the users for one bit is

$$\begin{aligned} y_1 &= A_1 d_1 + \rho_{2,1} A_2 d_2 + \rho_{3,1} A_3 d_3 + z_1 \\ y_2 &= \rho_{1,2} A_1 d_1 + A_2 d_2 + \rho_{3,2} A_3 d_3 + z_2 \\ y_3 &= \rho_{1,3} A_1 d_1 + \rho_{2,3} A_2 d_2 + A_3 d_3 + z_3 \end{aligned} \quad (4)$$

This can be written in the matrix-vector form

$$\begin{bmatrix} y_1 \\ y_2 \\ y_3 \end{bmatrix} = \begin{bmatrix} 1 & \rho_{2,1} & \rho_{3,1} \\ \rho_{1,2} & 1 & \rho_{3,2} \\ \rho_{1,3} & \rho_{2,3} & 1 \end{bmatrix} \begin{bmatrix} A_1 & 0 & 0 \\ 0 & A_2 & 0 \\ 0 & 0 & A_3 \end{bmatrix} \begin{bmatrix} d_1 \\ d_2 \\ d_3 \end{bmatrix} + \begin{bmatrix} z_1 \\ z_2 \\ z_3 \end{bmatrix} \quad (5)$$

or

$$\mathbf{y} = \mathbf{RAd} + \mathbf{z} \quad (6)$$

For a  $K$  user system, the vectors  $\mathbf{d}$ ,  $\mathbf{z}$ , and  $\mathbf{y}$ , are  $K$ -vectors that hold the data, noise, and matched filter outputs of all  $K$  users, respectively; the matrix  $\mathbf{A}$  is a diagonal matrix containing the corresponding received amplitudes; the matrix  $\mathbf{R}$  is a  $K \times K$  correlation matrix, whose entries contain the values of the correlations between every pair of codes. Note that since  $\rho_{i,k} = \rho_{k,i}$ , the matrix  $\mathbf{R}$  is clearly symmetric.

It is instructive to break up  $\mathbf{R}$  into two matrices: one representing the autocorrelations, the other the crosscorrelations. Therefore, parallel to Eq. (3), the conventional matched filter detector output can be expressed as three terms:

$$\mathbf{y} = \mathbf{Ad} + \mathbf{QAd} + \mathbf{z} \quad (7)$$

where  $\mathbf{Q}$  contains the off-diagonal elements (crosscorrelations) of  $\mathbf{R}$ , that is,  $\mathbf{R} = \mathbf{I} + \mathbf{Q}$  ( $\mathbf{I}$  is the identity matrix). The

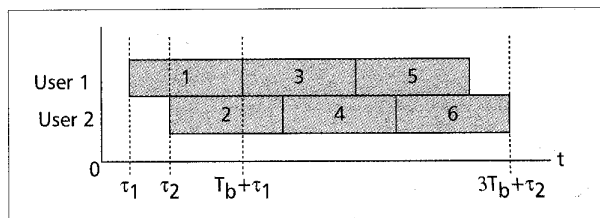

■ **Figure 2.** Sample timing diagram for an asynchronous channel. There are 2 users and 3 bits per user.

first term,  $\mathbf{Ad}$ , is simply the decoupled data weighted by the received amplitudes. The second term,  $\mathbf{QAd}$ , represents the MAI interference.

#### ASYNCHRONOUS CHANNEL

The detection problem in an asynchronous channel is more complicated than in a synchronous channel. In a synchronous channel, by definition, the bits of each user are aligned in time. Thus, detection can focus on one bit interval independent of the others (e.g., Eq. (3)); the detection of  $N$  bits of  $K$  users is equivalent to  $N$  separate "one-shot" detection problems. In most realistic applications, however, the channel is asynchronous and thus, there is overlap between bits of different intervals. Here, any decision made on a particular bit ideally needs to take into account the decisions on the 2 overlapping bits of each user; the decisions on these overlapping bits must then further take into account decisions on bits that overlap them and so on. Therefore, the detection problem must optimally be framed over the whole message [40].

The continuous-time model expressed in Eq. (1) can easily be modified for asynchronous channels by including the relative time delays (offsets) between signals. The received signal is now written as

$$r(t) = \sum_{k=1}^K A_k(t) g_k(t - \tau_k) d_k(t - \tau_k) + n(t) \quad (8)$$

where  $\tau_k$  is the delay for user  $k$ .

The discrete-time matrix-vector model describing the asynchronous channel takes the same form as Eq. (6). However, now the equation must encompass the entire message; thus, assuming there are  $N$  bits per user, the size of the vectors and the order of the matrices are  $NK$ . The vectors  $\mathbf{d}$ ,  $\mathbf{z}$ , and  $\mathbf{y}$  hold the data, noise, and matched filter outputs of all  $K$  users for all  $N$  bit intervals, and the matrix  $\mathbf{A}$  contains the corresponding received amplitudes. The matrix  $\mathbf{R}$  now contains the partial correlations that exist between every pair of the  $NK$  code words and is of size  $NK \times NK$ . We use the term partial correlations because in an asynchronous channel, the codes for each bit only partially overlap each other.

An example helps to illustrate our discussion. Consider the timing diagram of Fig. 2, where there are a total of two users and 3 bits per user. The output of the conventional detector can be described using Eq. (6), where we treat the problem as if there were six users (each transmitting 1 bit over the interval  $3T_b + \tau_2 - \tau_1$ ). The vectors  $\mathbf{d}$ ,  $\mathbf{z}$ , and  $\mathbf{y}$  hold the data, noise, and matched filter outputs associated with each of these 6 bits. The correlation matrix,  $\mathbf{R}$ , is of dimension  $6 \times 6$  and can be written as

$$\mathbf{R} = \begin{bmatrix} 1 & \rho_{2,1} & 0 & 0 & 0 & 0 \\ \rho_{1,2} & 1 & \rho_{3,2} & 0 & 0 & 0 \\ 0 & \rho_{2,3} & 1 & \rho_{4,3} & 0 & 0 \\ 0 & 0 & \rho_{3,4} & 1 & \rho_{5,4} & 0 \\ 0 & 0 & 0 & \rho_{4,5} & 1 & \rho_{6,5} \\ 0 & 0 & 0 & 0 & \rho_{5,6} & 1 \end{bmatrix} \quad (9)$$

where  $\rho_{i,k}$  is now the partial cross-correlation between the code associated with bit  $i$  and that associated with bit  $k$ ; in other

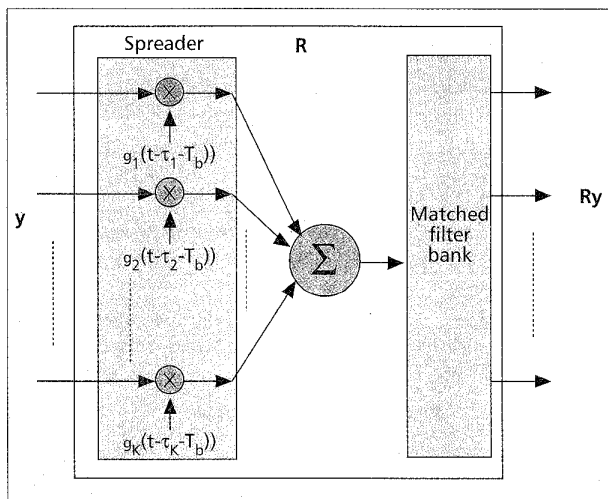

Figure 3. One stage of the polynomial expansion detector. The input is the matched filter bank output vector  $\mathbf{y}$  and the output is  $\mathbf{R}\mathbf{y}$ . A diagram of the matched filter bank is pictured in Fig. 1.

words, it denotes the cross-correlation between the overlapping part of code  $i$  and code  $k$ . Note that the 0 entries correspond to the correlations between bits that do not overlap. For a typical message length  $N$  is much greater than  $K$ ; hence, the correlation matrix is sparse because most of the  $NK$  bits do not overlap.

For the remainder of this article, an asynchronous channel is assumed unless otherwise stated. A more in-depth presentation of the mathematical details of the asynchronous channel can be found in [16, 18].

#### MAXIMUM-LIKELIHOOD SEQUENCE DETECTION

The detector which yields the most likely transmitted sequence,  $\mathbf{d}$ , chooses  $\mathbf{d}$  to maximize the probability that  $\mathbf{d}$  was transmitted given that  $r(t)$  was received, where  $r(t)$  extends over the whole message. This probability is referred to as the *joint a posteriori probability*,  $P(\mathbf{d}|r(t))$ , for all  $t$ ) [8]. Under the assumption that all possible transmitted sequences are equally probable, this detector is known as the maximum-likelihood sequence (MLS) detector [8].<sup>11-13</sup>

The problem with the MLS approach is that here there are  $2^{NK}$  possible  $\mathbf{d}$  vectors; an exhaustive search is clearly impractical for typical message sizes and numbers of users. However, it turns out that MLS detection can be implemented for DS-SS-CDMA by following the matched filter bank with a Viterbi algorithm [31].<sup>14</sup> This method parallels the use of the Viterbi algorithm to implement MLS detection in channels corrupted by intersymbol interference [8, 31]. Unfortunately, the required Viterbi algorithm has a complexity that is still exponential in the number of users, that is, on the order of  $2^K$ .<sup>15</sup>

Another disadvantage of the MLS detector is that it requires knowledge of the received amplitudes and phases. These values, however, are not known a priori, and must be estimated (e.g. [34-37]).

Despite the huge performance and capacity gains over conventional detection, the MLS detector is not practical. A realistic direct-sequence system has a relatively large number of active users; thus, the exponential complexity in the number of users makes the cost of this detector too high. In the remainder of this article we look at various suboptimal multi-user detectors that are simpler to implement.

#### LINEAR DETECTORS

An important group of multi-user detectors are linear multi-user detectors. These detectors apply a linear map-

ping,  $\mathbf{L}$ , to the soft output of the conventional detector to reduce the MAI seen by each user. In this section we briefly review the two most popular of these, the decorrelating and minimum mean-squared error detectors. We then examine the polynomial expansion detector, a linear detector recently proposed by the author that can efficiently implement both of the aforementioned detectors.

#### DECORRELATING DETECTOR

The decorrelating detector applies the inverse of the correlation matrix

$$\mathbf{L}_{\text{dec}} = \mathbf{R}^{-1} \quad (10)$$

to the conventional detector output in order to decouple the data. (Note that  $\mathbf{R}$  can be assumed to be invertible for asynchronous systems [40].) From Eq. (6), the soft estimate of this detector is

$$\begin{aligned} \hat{\mathbf{d}}_{\text{dec}} &= \mathbf{R}^{-1}\mathbf{y} = \mathbf{A}\mathbf{d} + \mathbf{R}^{-1}\mathbf{z} \\ &= \mathbf{A}\mathbf{d} + \mathbf{z}_{\text{dec}} \end{aligned} \quad (11)$$

which is just the decoupled data plus a noise term. Thus, we see that the decorrelating detector completely eliminates the MAI. This detector is very similar to the zero-forcing equalizer [8] which is used to completely eliminate ISI.

The decorrelating detector was initially proposed in [38, 39]. It is extensively analyzed by Lupas and Verdu in [40, 41], and is shown to have many attractive properties. Foremost among these properties are [16, 40, 41]:

- **Provides substantial performance/capacity gains over the conventional detector under most conditions.**<sup>16</sup>
- **Does not need to estimate the received amplitudes.** In contrast, detectors that require amplitude estimation are often quite sensitive to estimation error. (Note that as in the case of most multi-user detectors, the need to estimate the received phases can also be avoided through the use of noncoherent detection.<sup>9</sup>)
- **Has computational complexity significantly lower than that of the maximum likelihood sequence detector.** The per-bit complexity is linear in the number of users, excluding the costs of recomputation of the inverse mapping.

Other desirable features of the decorrelating detector are [16, 40, 41]:

- **Corresponds to the maximum likelihood sequence detector when the energies of all users are not known at the receiver.** In other words, it yields the joint maximum likelihood sequence estimation of the transmitted bits and their received amplitudes.
- **Has a probability of error independent of the signal energies.** This simplifies the probability of error analysis, and makes the decorrelating detector resistant to the near-far problem.
- **Yields the optimal value of the near-far resistance performance metric.**<sup>17</sup>
- **Can decorrelate one bit at a time.** For bit  $k$ , we only need apply the  $k$ th row of  $\mathbf{R}^{-1}$  to the matched filter bank outputs.

Because of its many advantages, the decorrelating detector has probably received the most attention of any multi-user detector in the literature. Many additional references can be found in [16-18].<sup>18</sup>

A disadvantage of this detector is that it causes noise enhancement (similar to the zero-forcing equalizer [8]). The power associated with the noise term  $\mathbf{R}^{-1}\mathbf{z}$  at the output of the decorrelating detector — Eq. (11) — is always greater than or equal to the power associated with the noise term at the output of the conventional detector — Eq. (6) — for each bit (proved in [44]). Despite this drawback, the decorrelating

detector generally provides significant improvements over the conventional detector.<sup>19</sup>

A more significant disadvantage of the decorrelating detector is that the computations needed to invert the matrix  $\mathbf{R}$  are difficult to perform in real time. For synchronous systems, the problem is somewhat simplified: we can decorrelate one bit at a time. In other words, we can apply the inverse of a  $K \times K$  correlation matrix. For asynchronous systems, however,  $\mathbf{R}$  is of order  $NK$ , which is quite large for a typical message length,  $N$ .

There have been numerous suboptimal approaches to implementing the decorrelating detector [16–18]. Many of them entail breaking up the detection problem into more manageable blocks [45–48, 79, 81] (possibly even to one transmission interval [16, 49]); the inverse matrix can then be exactly computed.<sup>20</sup> A  $K$ -input  $K$ -output linear filter implementation is also possible [40], where the filter coefficients are a function of the cross-correlations.<sup>21,22</sup>

Whichever suboptimal decorrelating detector technique is used, the computation required is substantial. Therefore, the use of codes that repeat each bit (“short” codes) is generally assumed so that the partial correlations between all signals are the same for each bit. This minimizes the need for recomputation of the matrix inverse or the filter coefficients from one bit interval to the next. Where recomputation cannot be avoided, (e.g., new user activation), research has been directed at trying to simplify the cost of recomputation (e.g. [52, 53]). The processing burden still appears to present implementation difficulties.

#### MINIMUM MEAN-SQUARED ERROR (MMSE) DETECTOR

The minimum mean-squared error (MMSE) detector [45] is a linear detector which takes into account the background noise and utilizes knowledge of the received signal powers. This detector implements the linear mapping which minimizes  $E[\|\mathbf{d} - \mathbf{L}\mathbf{y}\|^2]$ , the mean-squared error between the actual data and the soft output of the conventional detector. This results in [45, 84]

$$\mathbf{L}_{\text{MMSE}} = [\mathbf{R} + (N_0/2)\mathbf{A}^{-2}]^{-1} \quad (12)$$

Thus, the soft estimate of the MMSE detector is simply

$$\hat{\mathbf{d}}_{\text{MMSE}} = \mathbf{L}_{\text{MMSE}} \mathbf{y} \quad (13)$$

As can be seen, the MMSE detector implements a partial or modified inverse of the correlation matrix. The amount of modification is directly proportional to the background noise; the higher the noise level, the less complete an inversion of  $\mathbf{R}$  can be done without noise enhancement causing performance degradation. Thus, the MMSE detector balances the desire to decouple the users (and completely eliminate MAI) with the desire to not enhance the background noise. (Additional explanation can be found in [54].) This multi-user detector is exactly analogous to the MMSE linear equalizer used to combat ISI [8].

Because it takes the background noise into account, the MMSE detector generally provides better probability of error performance than the decorrelating detector. As the background noise goes to zero, the MMSE detector converges in performance to the decorrelating detector.<sup>23</sup>

An important disadvantage of this detector is that, unlike the decorrelating detector, it requires estimation of the received amplitudes. Another disadvantage is that its performance depends on the powers of the interfering users [45].

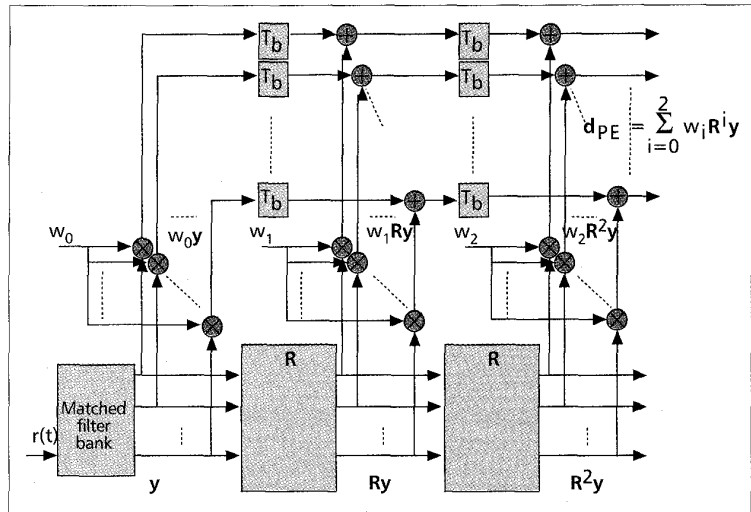

■ Figure 4. General DS-CDMA polynomial expansion detector with 2 stages.

Therefore, there is some loss of resistance to the near-far problem as compared to the decorrelating detector.

Like the decorrelating detector, the MMSE detector faces the task of implementing matrix inversion. Thus, most of the suboptimal techniques for implementing the decorrelating detector are applicable to this detector as well.<sup>24</sup>

#### POLYNOMIAL EXPANSION (PE) DETECTOR

The polynomial expansion (PE) detector [54, 55], applies a polynomial expansion in  $\mathbf{R}$  to the matched filter bank output,  $\mathbf{y}$ . Thus, the linear mapping for the PE detector is

$$\mathbf{L}_{\text{PE}} = \sum_{i=0}^{N_s} w_i \mathbf{R}^i \quad (14)$$

and the soft estimates of  $\mathbf{d}$  are given by

$$\hat{\mathbf{d}}_{\text{PE}} = \mathbf{L}_{\text{PE}} \mathbf{y} \quad (15)$$

For a given  $\mathbf{R}$  and  $N_s$ , the weights (polynomial coefficients)  $w_i$ ,  $i = 0, 1, \dots, N_s$ , can be chosen to optimize some performance measure.

The structure which implements the matrix  $\mathbf{R}$  is shown in Fig. 3, and the full detector (with two stages) is shown in Fig. 4. Each stage implements  $\mathbf{R}$  by recreating the overall modulation (spreading), noiseless channel (summing), and demodulation (matched filtering) process. The fact that this implements  $\mathbf{R}$  is clear from the expression for the noiseless conventional detector output,  $\mathbf{y} = \mathbf{R}\mathbf{A}\mathbf{d}$  (Eq. (6)). Cascading these stages produces higher-order terms of the polynomial. A two-stage PE detector is shown in Fig. 4; the detector corresponding to Eq. (14) requires  $N_s$  stages.

It can be shown (by the Cayley-Hamilton Theorem) that the PE detector structure can exactly implement the decorrelating detector for finite message length,  $N$  [54]. However, for typical  $N$  this would require a prohibitive number of stages. As  $N \rightarrow \infty$ , infinite stages would be needed, with one bit delay required per stage.<sup>25</sup> Fortunately, good approximations can be obtained with a relatively small number of stages. Therefore, we can choose  $\mathbf{w} = [w_0 \ w_1 \ \dots \ w_{N_s}]$  so that

$$\mathbf{p}(\mathbf{R}) = \sum_{i=0}^{N_s} w_i \mathbf{R}^i \approx \mathbf{R}^{-1} \quad (16)$$

The resulting weights are used in the structure of Fig. 4 to yield a  $K$ -input  $K$ -output finite memory-length detector, which approximates the decorrelating detector.

The PE detector structure can also be used to approximate the MMSE detector, as described in [54].

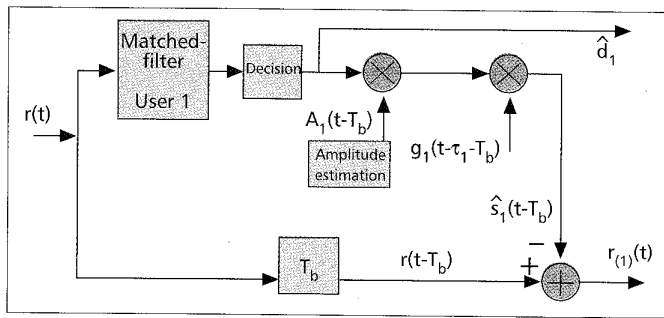

■ Figure 5. SIC detection – first stage (hard decision).

The polynomial expansion detector has a number of attractive features [54, 55]:

- **Can approximate the decorrelating and MMSE detectors.** As such, it can enjoy the desirable features of these two detectors, which were discussed earlier.
- **Has low computational complexity.** In approximating the decorrelating (or MMSE) detector, neither the matrix  $\mathbf{R}$  nor its inverse must be explicitly calculated. Everything can be implemented on-line, using anything from analog hardware to DSP chips.
- **Does not need to estimate the received amplitudes (or phases).** This important feature, which is true for the decorrelating detector, is also true for the PE detector in approximating the decorrelating detector. (If the PE detector is approximating the MMSE detector, however, amplitude estimation will be necessary).
- **Can be implemented just as easily using long codes as short codes.** (See [51] which points out a problem with using short codes.)
- **Can use weights that work well over a large variation of system parameters.** As shown in [54], the use of additional stages in the PE detector (a higher order polynomial) allows more flexibility to use pre-computed weights that work well over a broad operating range. This minimizes or eliminates the need to adapt the weights to changes in the operating environment.
- **Has a relatively simple structure.** The types of system components used are the same as those of the conventional detector. The amount of system components increases linearly with the product of the number of users and the number of stages. As we will see in the next section, the structure is very similar to that of the parallel interference cancellation detector structure. In that structure, each stage contains a modulator (spreader) a *partial* summer, and a demodulator (matched-filter bank), which implements the matrix  $\mathbf{Q}$  ( $\mathbf{R}$  with its main diagonal removed).

## SUBTRACTIVE INTERFERENCE CANCELLATION

Another important group of detectors can be classified as subtractive interference cancellation detectors. The basic principle underlying these detectors is the creation at the receiver of separate estimates of the MAI contributed by each user in order to subtract out some or all of the MAI seen by each user. Such detectors are often implemented with multiple stages, where the expectation is that the decisions will improve at the output of successive stages.

These detectors are similar to feedback equalizers [8] used to combat ISI. In feedback equalization, decisions on previously detected symbols are fed back in order to cancel part of the ISI. Thus, a number of these types of multi-user detectors are also referred to as decision-feedback detectors.

The bit decisions used to estimate the MAI can be hard or soft. The soft-decision approach uses soft data estimates for the joint estimation of the data and amplitudes, and is easier to implement.<sup>26</sup> The hard-decision approach feeds back a bit decision and is nonlinear; it requires reliable estimates of the received amplitudes in order to generate estimates of the MAI. If reliable amplitude estimation is possible, hard-decision subtractive interference cancellation detectors generally outperform their soft-decision counterparts. However, studies such as [56, 57] indicate that the need for amplitude estimation is a significant liability of the hard-decision techniques: imperfect amplitude estimation may significantly reduce or even reverse the performance gains available.

We briefly review several subtractive interference cancellation detectors below. Additional references can be found in two surveys which focus on these detectors [58, 59] and in the general surveys [16–18].

### SUCCESSIVE INTERFERENCE CANCELLATION (SIC)

The successive interference cancellation (SIC) detector [60, 68] takes a serial approach to canceling interference. Each stage of this detector decisions, regenerates, and cancels out one additional direct-sequence user from the received signal, so that the remaining users see less MAI in the next stage. (Note that the basic concept behind this approach can be found earlier in information theory [61–63].)

A simplified diagram of the first stage of this detector is shown in Fig. 5, where a hard-decision approach is assumed. The first stage is preceded by an operation which ranks the signals in descending order of received powers (not shown). The first stage implements the following steps:

1. Detect with the conventional detector the strongest signal,  $s_1$ .
2. Make a hard data decision on  $s_1$ .
3. Regenerate an estimate of the received signal for user one,  $\hat{s}_1(t)$ , using:
  - Data decision from step 2
  - Knowledge of its PN sequence
  - Estimates of its timing and amplitude (and phase)<sup>9</sup>
4. Cancel (subtract out)  $\hat{s}_1(t)$  from the total received signal,  $r(t)$ , yielding a partially cleaned version of the received signal,  $r_{(1)}(t)$ .

Assuming that the estimation of  $\hat{s}_1(t)$  in step 3 above was accurate, the outputs of the first stage are:

1. A data decision on the strongest user
2. A modified received signal without the MAI caused by the strongest user

This process can be repeated in a multistage structure: the  $k$ th stage takes as its input the “partially cleaned” received signal output by the previous stage,  $r_{(k-1)}(t)$ , and outputs one additional data decision (for signal  $s_k$ ) and a “cleaner” received signal,  $r_{(k)}(t)$ .<sup>27, 28</sup>

The reasons for canceling the signals in descending order of signal strength are straightforward [17, 68]. First, it is easiest to achieve acquisition and demodulation on the strongest users (best chance for a correct data decision). Second, the removal of the strongest users gives the most benefit for the remaining users. The result of this algorithm is that the strongest user will not benefit from any MAI reduction; the weakest users, however, will potentially see a huge reduction in their MAI.<sup>29</sup>

The SIC detector requires only a minimal amount of additional hardware and has the potential to provide significant improvement over the conventional detector. It does, however, pose a couple of implementation difficulties. First, one additional bit delay is required per stage of cancellation. Thus,

a trade-off must be made between the number of users that are canceled and the amount of delay that can be tolerated [64]. Second, there is a need to reorder the signals whenever the power profile changes [64]. Here, too, a trade-off must be made between the precision of the power ordering and the acceptable processing complexity.

A potential problem with the SIC detector occurs if the initial data estimates are not reliable. In this case, even if the timing, amplitude, and phase estimates are perfect, if the bit estimate is wrong, the interfering effect of that bit on the signal-to-noise ratio is quadrupled in power (the amplitude doubles, so the power quadruples). Thus, a certain minimum performance level of the conventional detector is required for the SIC detector to yield improvements; it is crucial that the data estimates of at least the strong users that are canceled first be reliable.

#### PARALLEL INTERFERENCE CANCELLATION

In contrast to the SIC detector, the parallel interference cancellation (PIC) detector estimates and subtracts out all of the MAI for each user in parallel. The multistage PIC structure which we assume here was introduced in [67]. A basic one stage PIC structure is assumed in [68, 69] and several earlier references (see [18]).

The first stage of this detector is pictured in Fig. 6, where a hard-decision approach is assumed. The initial bit estimates,  $\hat{d}_i(0)$ , are derived from the matched filter detector (not shown), which we refer to as stage 0 of this detector. These bits are then scaled by the amplitude estimates and respread by the codes, which produces a delayed estimate of the received signal for each user,  $\hat{s}_k(t - T_b)$ . The partial summer sums up all but one input signal at each of the outputs, which creates the complete MAI estimate for each user.

Assuming perfect amplitude and delay estimation, the result after subtracting the MAI estimate for user  $k$  is

$$r(t - T_b) - \sum_{i \neq k} \hat{s}_i(t - T_b) = d_k(t - \tau_k - T_b)A_k(t - \tau_k - T_b)g_k(t - \tau_k - T_b) + n(t - T_b) + \sum_{i \neq k} (d_i(t - \tau_i - T_b) - \hat{d}_i(t - \tau_i - T_b))A_i(t - \tau_i - T_b)g_i(t - \tau_i - T_b) \quad (17)$$

As shown in Fig. 6, the result of Eq. (17) (for  $k = 1 \dots K$ ) is passed on to a second bank of matched filters to produce a new, hopefully better, set of data estimates.

This process can be repeated for multiple stages. Each stage takes as its input the data estimates of the previous stage and produces a new set of estimates at its output. We can use a matrix-vector formulation to compactly express the soft output of stage  $m + 1$  of the PIC detector for all  $N$  bits of all  $K$  users as [70]

$$\hat{\mathbf{d}}(m + 1) = \mathbf{y} - \mathbf{Q}\hat{\mathbf{A}}\hat{\mathbf{d}}(m) = \mathbf{A}\mathbf{d} + \mathbf{Q}\mathbf{A}(\mathbf{d} - \hat{\mathbf{d}}(m)) + \mathbf{z} \quad (18)$$

The term  $\mathbf{Q}\hat{\mathbf{A}}\hat{\mathbf{d}}(m)$  represents an estimate of the MAI (7). (As

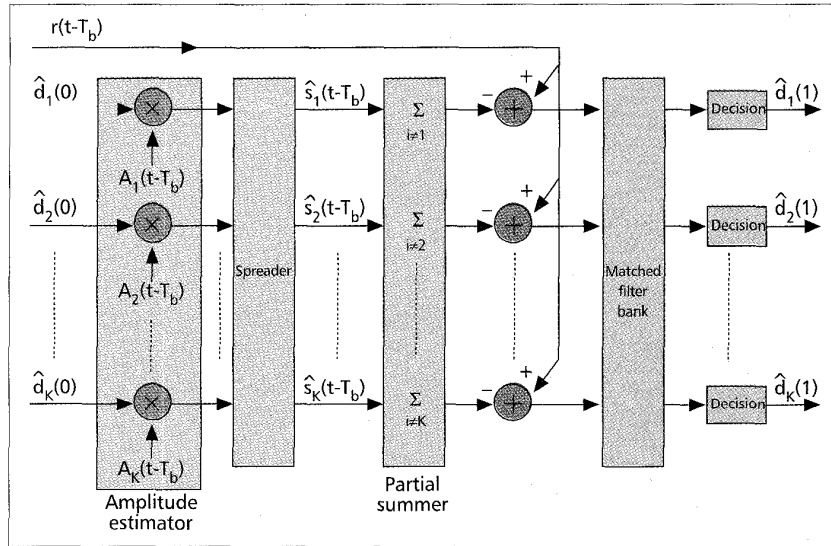

■ **Figure 6.** One stage of a PIC detector (hard decision) for  $K$  users. The initial stage (conventional detector) is not shown; it introduces one bit delay, which is why the received signal and the amplitudes are delayed by  $T_b$ . The spreader is defined in Fig. 3 and the matched filter bank is defined in Fig. 1.

usual, for BPSK, the hard data decisions,  $\hat{d}(m)$ , are made according to the signs of the soft outputs,  $\hat{\mathbf{d}}(m)$ .) Perfect data estimates, coupled with our assumption of perfect amplitude and delay estimation, result in the complete elimination of MAI.<sup>30</sup>

A number of studies have investigated PIC detection which utilizes soft decisions, such as [55, 72, 76, 86]. In [72] soft-decision PIC and SIC detectors are compared; since soft-decision SIC exploits power variation by canceling in order of signal strength, it is found to be superior in a non-power-controlled fading channel. On the other hand, soft-decision PIC is found to be superior in a well-power-controlled channel.

A number of variations on the PIC detector have been proposed for improved performance. These include the following.

#### Using the Decorrelating Detector as the First Stage

**[70]** — The performance of the PIC detector depends heavily on the initial data estimates [67]. As we pointed out for the SIC detector, the subtraction of an interfering bit based on an incorrect bit estimate causes a quadrupling in the interfering power for that bit. Thus, too many incorrect initial data estimates may cause performance to degrade relative to the conventional detector (no cancellation may be better than poor cancellation). Therefore, using the decorrelating detector as the first stage significantly improves the performance of the PIC detector. (An additional benefit from this approach is that the performance analysis is found to be much simplified.)<sup>31, 32</sup>

#### Using the Already Detected Bits at the Output of the Current Stage to Improve Detection of the Remaining Bits in the Same Stage

**[74]** — Thus, the most up-to-date bit decisions available are always used. This contrasts with the standard PIC detector, which only uses the previous stage's decisions. This detector is referred to as a multistage decision feedback detector [74]. Proposals for the initial stage of this detector include a decision-feedback detector [74], the conventional detector [45], and the decorrelating detector [78].<sup>33</sup>

#### Linearly Combining the Soft-Decision Outputs of Different Stages of the PIC Detector

**[55]** — This simple



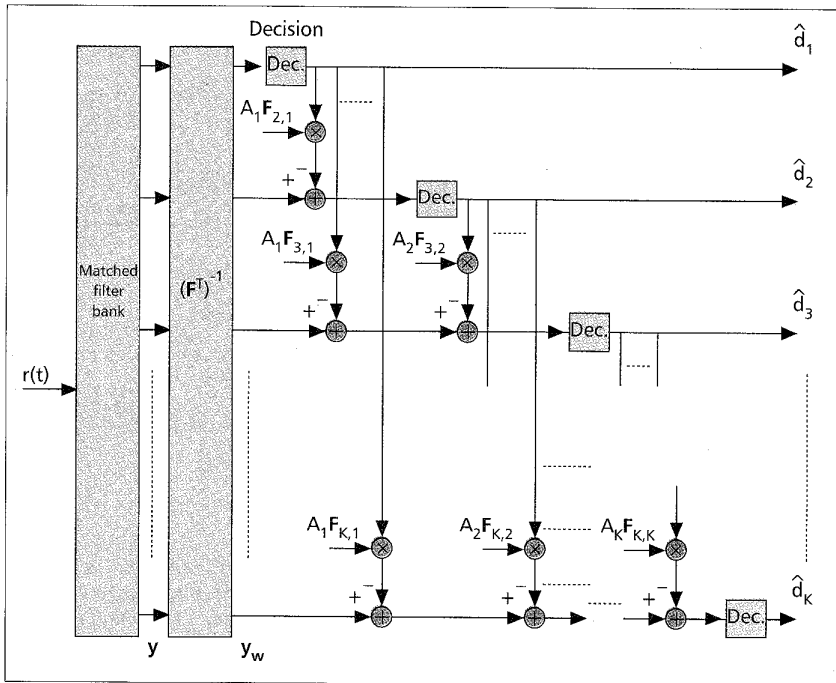

■ Figure 7. The ZF-DF detector. A form of SIC is performed on the whitened matched filter output.

modification yields very large gains in performance over the standard soft-decision PIC detector. The reason for this has to do with the extensive noise correlations that exist between outputs of different stages. The linear combination is made in such a way as to capitalize on the noise correlations and cause cancellation among noise terms.

**Doing a Partial MAI Cancellation at Each Stage, with the Amount of Cancellation Increasing for Each Successive Stage [76]** — Thus, the MAI estimate is first scaled by a fraction before cancellation; the value of the fraction increases for successive stages. This takes into account the fact that the tentative decisions of the earlier stages are less reliable than those of the later stages. Huge gains in performance and capacity are reported over the standard (“brute force”) PIC detector. This recently proposed detector may be the most powerful of the subtractive interference cancellation detectors, and needs to be studied further.

#### ZERO-FORCING DECISION-FEEDBACK (ZF-DF) DETECTOR

The zero-forcing decision-feedback (ZF-DF) detector (also referred to as the decorrelating DF detector)[77–79, 81] performs two operations: linear preprocessing followed by a form of SIC detection. The linear operation *partially* decorrelates the users (without enhancing the noise), and the SIC operation decisions and subtracts out the interference from one additional user at a time, in descending order of signal strength. As we describe below, the initial partial decorrelation enables the SIC operation to be much more powerful.

The ZF-DF detector is based on a white noise channel model. A noise-whitening filter is obtained by factoring  $\mathbf{R}$  by the Cholesky decomposition [83],  $\mathbf{R} = \mathbf{F}^T \mathbf{F}$ , where  $\mathbf{F}$  is a lower triangular matrix. Applying  $(\mathbf{F}^T)^{-1}$  to the matched filter bank outputs of Eq. (6) yields the white noise model [77]

$$\mathbf{y}_w = \mathbf{F}\mathbf{A}\mathbf{d} + \mathbf{z}_w \quad (19)$$

where the covariance matrix of the noise term,  $\mathbf{z}_w$ , is  $(N_0/2)\mathbf{I}$  (white noise). (This is similar to the white noise model that is derived for ISI channels [8].)

In the white noise model of Eq. (19), the data bits are partially decorrelated. This can be shown to arise from the fact that the matrix  $\mathbf{F}$  is lower triangular [77]. Thus, the output for bit one of the first user contains no MAI; the output for bit one of the second user contains MAI only from bit one of the first user, and is completely decorrelated from all other users; similarly, the output for user  $k$  at bit interval  $i$  is completely decorrelated from users  $k + 1, k + 2, \dots, K$ , at time  $i$ , and from all bits at future time intervals.

The ZF-DF detector uses SIC detection to exploit the partial decorrelation of the bits in the white noise model. The soft output of bit one of the first user, which is completely free of MAI, is used to regenerate and cancel out the MAI it causes, thereby leaving the soft output of bit one of the second user also free of MAI (decorrelated). This process continues: for each iteration, the MAI contributed by one additional bit (the

previously decorrelated bit) is regenerated and canceled, thereby yielding one additional decorrelated bit.

Prior to forming and applying  $(\mathbf{F}^T)^{-1}$  to create the white noise model, the users are ordered according to their signal strength, thus insuring that interference cancellation takes place in descending order of signal strength. This maximizes the gains to be had from SIC detection, as discussed earlier.

A diagram of the ZF-DF detector is shown in Fig. 7, where we assume a synchronous channel for clarity.<sup>34</sup> In a synchronous channel we can deal with one bit interval at a time; hence, the size of the vectors and the order of  $\mathbf{F}$  in Eq. (19) are reduced to  $K$ . Assuming perfect estimates of  $\mathbf{F}$  and the received amplitudes, the soft output for the  $k$ th user is [77]

$$\hat{d}_k = y_{w,k} - \sum_{i=0}^{k-1} \mathbf{F}_{k,i} A_i \hat{d}_i \quad (20)$$

where  $\hat{d}_i = \text{sign}[\hat{d}_i]$  are the previously detected bits (of the stronger users),  $A_i$  is the received amplitude of this bit, and  $\mathbf{F}_{k,i}$  is the  $(k, i)$ th element of  $\mathbf{F}$ .

Under the assumption that all past decisions are correct, the ZF-DF detector eliminates all MAI and maximizes the signal-to-noise ratio [78].<sup>35</sup> It is analogous to the ZF-DF equalizer used to combat ISI.<sup>36, 37</sup>

An important difficulty with the ZF-DF detector is the need to compute the Cholesky decomposition<sup>38</sup> and the whitening filter  $(\mathbf{F}^T)^{-1}$  (matrix inversion). Attempts to simplify its implementation are similar to those of the decorrelating detector.

The ZF-DF detector, like the other nonlinear detectors, has the disadvantage of needing to estimate the received signal amplitudes. If the soft outputs of the decorrelating detector are used to estimate the amplitudes, the ZF-DF detector is equivalent to the decorrelating detector [78]. If the amplitude estimates are more reliable than those produced by the decorrelating detector, the ZF-DF detector performs better than the decorrelating detector; if less reliable, however, the ZF-DF detector performs worse than the decorrelating detector.

## SUMMARY AND CONCLUSION

Multiple access interference significantly limits the performance and capacity of conventional DS-CDMA systems. Much research has been directed at mitigating this problem through the design of multi-user detectors.

In multi-user detection, code and timing information of multiple users is jointly used to better detect each individual user. The optimum multi-user sequence detector is known, and provides huge gains in performance and capacity over the conventional detector; it also minimizes the need for power control. Unfortunately, it is too complex to implement for practical DS-CDMA systems.

Many simpler suboptimal multi-user detectors have been proposed in the last few years, all of which have the potential to provide substantial performance and capacity gains over the conventional detector. Most of the detectors fall into two categories: linear and subtractive interference cancellation.

### LINEAR DETECTORS

Linear multi-user detectors, which include the decorrelating, minimum mean-squared error (MMSE), and polynomial expansion (PE) detectors, apply a linear transformation to the outputs of the matched filter bank to reduce the MAI seen by each user.

The decorrelating detector applies the inverse of the correlation matrix to the matched filter bank outputs, thereby decoupling the signals. It has many desirable features, including its ability to be implemented without knowledge of the received amplitudes.

The MMSE detector applies a modified inverse of the correlation matrix to the matched filter bank outputs. It yields a better error rate performance than the decorrelating detector, but it requires estimation of the received powers.

Both the decorrelating and MMSE detectors require non-trivial computations that are a function of the cross-correlations. This is particularly difficult for the case of long (time-varying) codes, where the cross-correlations change each bit. Many proposals for simplifying the necessary computations have been made, but difficulties remain.

The polynomial expansion detector applies a polynomial expansion in the correlation matrix to the outputs of the matched filter bank. This detector has the important advantage that it can efficiently approximate either the decorrelating or MMSE detectors; in doing so, neither the correlation matrix nor its inverse needs to be explicitly calculated. Like the decorrelating detector, it does not need to estimate the received amplitudes. Unlike the decorrelating detector, it can easily be implemented with long codes. Also, it appears that weights (polynomial coefficients) can be chosen that are fairly robust over a wide range of system parameters, thereby minimizing or eliminating the need for adaptation.

### SUBSTRUCTIVE INTERFERENCE CANCELLATION DETECTORS

Subtractive interference cancellation detectors attempt to estimate and subtract off the MAI. These detectors include the successive interference cancellation (SIC), parallel interference cancellation (PIC), and zero-forcing decision-feedback (ZF-DF) detectors.

The bit decisions used to estimate the MAI may be either hard decisions or soft decisions. Soft decisions provide a joint estimate of data and amplitude and are easier to implement. If reliable channel estimates are available, however, hard-decision (nonlinear) schemes perform better than their soft-decision counterparts.

The SIC detector takes a serial approach to subtracting out the MAI: it decides, regenerates, and cancels out one addi-

tional direct-sequence user at a time. In contrast, the PIC detector estimates and subtracts out all of the MAI for each user in parallel. Both of these detectors may be implemented with a variable number of stages.

From the work in [72], it appears that the SIC detector performs better than the PIC detector in a fading environment, while the reverse is true in a well-power-controlled environment, (although this work has been done specifically for the case of soft decisions). The PIC detector requires more hardware, but the SIC detector faces the problems of power reordering and large delays.

Various methods for improving PIC detection have been proposed. The recently proposed improved PIC detector of [76] may be the most powerful of the subtractive interference cancellation detectors, and needs to be studied further.

Several detectors combine linear preprocessing with subtractive interference cancellation. Examples are the ZF-DF detector and a PIC detector with a decorrelating detector as the first stage. A significant disadvantage of the ZF-DF detector is that it requires Cholesky factorization and matrix inversion.

A major disadvantage of nonlinear detectors is their dependence on reliable estimates of the received amplitudes. Studies such as [56, 57] indicate that imperfect amplitude estimation may significantly reduce or even reverse the gains to be had from using these detectors.

## CONCLUSION

Multi-user detection holds much promise for improving DS-CDMA performance and capacity. Although multi-user detection is currently in the research stage, efforts to commercialize multi-user detectors are expected in the coming years as DS-CDMA systems are more widely deployed. The success of these efforts will depend on the outcome of careful performance and cost analyses for the realistic environment.

## ACKNOWLEDGMENT

The author sincerely thanks Dr. Mahesh Varanasi, Dr. Ken Smolik, Dr. Zoran Siveski, Dr. Howard Sherry, Dr. Joseph Wilkes, and Dr. Larry Ozarow for their helpful comments. The author also expresses his warm appreciation to his wife, Adina, for her help in editing this article.

## REFERENCES

- [1] A. J. Viterbi, "The Orthogonal-Random Waveform Dichotomy for Digital Mobile Personal Communications," *IEEE Pers. Commun.*, 1st qtr., 1994, pp. 18-24.
- [2] W. C. Y. Lee, "Overview of Cellular CDMA," *IEEE Trans. Vehic. Tech.*, vol. 40, no. 2, May 1991, pp. 291-302.
- [3] K. S. Gilhousen et al., "On the Capacity of a Cellular CDMA System," *IEEE Trans. Vehic. Tech.*, vol. 40, no. 2, May 1991, pp. 303-12.
- [4] R. L. Pickholtz, L. B. Milstein, and D. L. Schilling, "Spread Spectrum for Mobile Communications," *IEEE Trans. Vehic. Tech.*, vol. 40, no. 2, May 1991, pp. 313-22.
- [5] V. K. Garg, K. Smolik, and J. E. Wilkes, *Applications of Code-Division Multiple Access (CDMA) in Wireless/Personal Communications*, Upper Saddle River, NJ: Prentice Hall, 1996.
- [6] H. V. Poor and L. A. Rusch, "Narrowband Interference Suppression in Spread Spectrum CDMA," *IEEE Pers. Commun.*, 3rd qtr., 1994, pp. 14-27.
- [7] L. A. Rusch and H. V. Poor, "Multi-User Detection Techniques for Narrowband Interference Suppression in Spread Spectrum Communications," *IEEE Trans. Commun.*, vol. 43, no. 2/3/4, Feb./Mar./Apr. 1995, pp. 1725-37.
- [8] J. G. Proakis, *Digital Communications*, 2nd ed., New York: McGraw-Hill, 1989.
- [9] M. B. Pursley, "Performance Evaluation for Phase-Coded Spread-Spectrum Multiple-Access Communication — Part I: System Analysis," *IEEE Trans. Commun.*, vol. COM-25, no. 8, Aug. 1977, pp. 795-99.
- [10] K. Yao, "Error Probability of Asynchronous Spread Spectrum Multiple Access Communication Systems," *IEEE Trans. Commun.*, vol. COM-25, no. 8, Aug. 1977, pp. 803-9.
- [11] D. V. Sarwate and M. B. Pursley, "Crosscorrelation Properties of Pseudorandom and Related Sequences," *Proc. IEEE*, vol. 68, no. 5, May

- 1980, pp. 593-619.
- [12] R. Kohno, "Pseudo-Noise Sequences and Interference Cancellation Techniques for Spread Spectrum Systems," *IEICE Trans. Commun.*, vol. J74-B-1, no. 5, May 1991, pp. 1083-92. Reprinted in *Multiple Access Communications: Foundations for Emerging Technologies*, N. Abramson, ed., IEEE Press, 1993.
- [13] J. M. Holtzman, "CDMA Power Control for Wireless Networks," *Third Generation Wireless Information Networks*, D. G. Goodman and S. Nanda, eds., Norwell, MA: Kluwer, 1992, pp. 299-311.
- [14] J. C. Liberti, "Spatial Processing for High Tier Wireless Systems," Bellcore Pub. IM-558, Sept. 1996.
- [15] S. Verdú, "Adaptive Multi-User Detection," *Code Division Multiple Access Communications*, S. G. Glisic and P. A. Leppanen, Eds., pp. 97-116, The Netherlands: Kluwer, 1995.
- [16] S. Verdú, "Multi-User Detection," *Advances in Statistical Signal Processing*, vol. 2, JAI Press 1993, pp. 369-409.
- [17] A. Duel-Hallen, J. Holtzman, and Z. Zvonar, "Multi-User Detection for CDMA Systems," *IEEE Pers. Commun.*, vol. 2, no. 2, Apr. 1995, pp. 46-58.
- [18] S. Moshavi, "Survey of Multi-User Detection for DS-CDMA Systems," Bellcore pub., IM-555, Aug. 1996.
- [19] Z. Zvonar and D. Brady, "Linear Multipath-Decorrelating Receivers for CDMA Frequency-Selective Fading Channels," *IEEE Trans. Commun.*, vol. 44, no. 6, June 1996, pp. 650-53.
- [20] Z. Zvonar and D. Brady, "Suboptimal Multi-User Detector for Frequency-Selective Rayleigh Fading Synchronous CDMA Channels," *IEEE Trans. Commun.*, vol. 43, no. 2/3/4, Feb./Mar./Apr. 1995, pp. 154-57.
- [21] Z. Zvonar, "Multi-User Detection and Diversity Combining for Wireless CDMA Systems," *Wireless and Mobile Communications*, J. Holtzman and D. Goodman, eds., Boston: Kluwer, 1994, pp. 51-65.
- [22] Z. Zvonar, "Combined Multi-User Detection and Diversity Reception for Wireless CDMA Systems," *IEEE Trans. Vehic. Tech.*, vol. 45, no. 1, Feb. 1996, pp. 205-11.
- [23] H. C. Huang and S. C. Schwartz, "A Comparative Analysis of Linear Multi-User Detectors for Fading Multipath Channels," *Proc. IEEE Globecom '94*, San Francisco, CA, Nov. 1994, pp. 11-15.
- [24] Y. C. Yoon, R. Kohno, and H. Imai, "A Spread-Spectrum Multi-Access System with Cochannel Interference Cancellation for Multipath Fading Channels," *IEEE JSAC*, vol. 11, no. 7, Sept. 1993, pp. 1067-75.
- [25] P. M. Grant, S. Mowbray, and R. D. Pringle, "Multipath and Cochannel CDMA Interference Cancellation," *Proc. IEEE 2nd Int'l. Symp. on Spread Spectrum Techniques and Apps. (ISSSTA '92)*, Yokohama, Japan, Dec. 1992, pp. 83-86.
- [26] M. K. Varanasi and S. Vasudevan, "Multi-User Detectors for Synchronous CDMA Communications over Non-Selective Rician Fading Channels," *IEEE Trans. Commun.*, vol. 42, no. 2/3/4, Feb./Mar./Apr. 1994, pp. 711-22.
- [27] S. Vasudevan, and M. K. Varanasi, "Optimum Diversity Combiner Based Multi-User Detection for Time-Dispersive Rician Fading CDMA Channels," *IEEE JSAC*, vol. 12, no. 4, May 1994, pp. 580-92.
- [28] M. K. Varanasi and B. Aazhang, "Optimally Near-Far Resistant Multi-User Detection in Differentially Coherent Synchronous Channels," *IEEE Trans. Info. Theory*, vol. 37, no. 4, July 1991, pp. 1006-18.
- [29] M. K. Varanasi, "Noncoherent Detection in Asynchronous Multi-User Channels," *IEEE Trans. Info. Theory*, vol. 39, no. 1, Jan. 1993, pp. 157-76.
- [30] Z. Zvonar and D. Brady, "Multi-User Detection in Single-Path Fading Channels," *IEEE Trans. Commun.*, vol. 42, no. 2/3/4, Feb./Mar./Apr. 1994, pp. 1729-39.
- [31] S. Verdú, "Minimum Probability of Error for Asynchronous Gaussian Multiple-Access Channels," *IEEE Trans. Info. Theory*, vol. IT-32, no. 1, Jan. 1986, pp. 85-96.
- [32] S. Verdú, "Minimum Probability of Error for Asynchronous Multiple Access Communication Systems," *Proc. IEEE MILCOM '83*, vol. 1, Nov. 1983, pp. 213-19.
- [33] Z. Xie, C. K. Rushforth, and R. T. Short, "Multi-User Signal Detection Using Sequential Decoding," *IEEE Trans. Commun.*, vol. 38, no. 5, May 1990, pp. 578-83.
- [34] H. V. Poor, "On Parameter Estimation in DS/SSMA Formats," *Lecture Notes in Control and Information Sciences - Advances in Communications and Signal Processing*, Springer Verlag, 1989, pp. 59-70.
- [35] Z. Xie et al., "Joint Signal Detection and Parameter Estimation in Multi-User Communications," *IEEE Trans. Commun.*, vol. 41, no. 7, Aug. 1993, pp. 1208-16.
- [36] Y. Steinberg and H. V. Poor, "Sequential Amplitude Estimation in Multi-User Communications," *IEEE Trans. Info. Theory*, vol. 40, no. 1, Jan. 1994, pp. 11-20.
- [37] T. K. Moon et al., "Parameter Estimation in a Multi-User Communication System," *IEEE Trans. Commun.*, vol. 42, no. 8, Aug. 1994, pp. 2553-60.
- [38] K. S. Schneider, "Optimum Detection of Code Division Multiplexed Signals," *IEEE Trans. Aerospace Elect. Sys.*, vol. AES-15, no., Jan. 1979, pp. 181-85.
- [39] R. Kohno, M. Hatori, and H. Imai, "Cancellation Techniques of Co-Channel Interference in Asynchronous Spread Spectrum Multiple Access Systems," *Elect. and Commun. in Japan*, vol. 66-A, no. 5, 1983, pp. 20-29.
- [40] R. Lupas and S. Verdú, "Near-Far Resistance of Multi-User Detectors in Asynchronous Channels," *IEEE Trans. Commun.*, vol. 38, no. 4, Apr. 1990, pp. 496-508.
- [41] R. Lupas and S. Verdú, "Linear Multi-User Detectors for Synchronous Code-Division Multiple-Access Channels," *IEEE Trans. Info. Theory*, vol. 35, no. 1, Jan. 1989, pp. 123-36.
- [42] M. K. Varanasi, "Group Detection for Synchronous Gaussian Code-Division Multiple-Access Channels," *IEEE Trans. Info. Theory*, vol. 41, no. 4, July 1995, pp. 1083-96.
- [43] M. K. Varanasi, "Parallel Group Detection for Synchronous CDMA Communication over Frequency Selective Rayleigh Fading Channels," *IEEE Trans. Info. Theory*, vol. 42, no. 1, Jan. 1996, pp. 116-28.
- [44] R. Lupas-Golaszewski and S. Verdú, "Asymptotic Efficiency of Linear Multi-User Detectors," *Proc. 25th Conf. on Decision and Control*, Athens, Greece, Dec. 1986, pp. 2094-2100.
- [45] Z. Xie, R. T. Short, and C. K. Rushforth, "A Family of Suboptimum Detectors for Coherent Multi-User Communications," *IEEE JSAC*, vol. 8, no. 4, May 1990, pp. 683-90.
- [46] S. S. H. Wijayasuriya, G. H. Norton, and J. P. McGeehan, "A Near-Far Resistant Sliding Window Decorrelating Algorithm for Multi-User Detectors in DS-CDMA Systems," *Proc. IEEE Globecom '92*, Dec. 1992, pp. 1331-38.
- [47] A. Kajiwara and M. Nakagawa, "Microcellular CDMA System with a Linear Multi-User Interference Canceller," *IEEE JSAC*, vol. 12, no. 4, May 1994, pp. 605-11.
- [48] F. Zheng and S. K. Barton, "Near Far Resistant Detection of CDMA Signals via Isolation Bit Insertion," *IEEE Trans. Commun.*, vol. 43, no. 2/3/4, Feb./Mar./Apr. 1995, pp. 1313-17.
- [49] A. Kajiwara and M. Nakagawa, "Crosscorrelation Cancellation in SS/DS Block Demodulator," *IEICE Trans.*, vol. E 74, no. 9, Sept. 1991, pp. 2596-2601.
- [50] D. S. Chen and S. Roy, "An Adaptive Multi-User Receiver for CDMA Systems," *IEEE JSAC*, vol. 12, no. 5, June 1994, pp. 808-16.
- [51] S. Vembu, and A. J. Viterbi, "Two Different Philosophies in CDMA — A Comparison," *Proc. IEEE Vehic. Tech. Conf. 1996 (VTC '96)*, Atlanta, GA, Apr. 28-May 1, 1996, pp. 869-73.
- [52] S. S. H. Wijayasuriya, G. H. Norton and J. P. McGeehan, "A Novel Algorithm for Dynamic Updating of Decorrelating Coefficients in Mobile DS-CDMA," *Proc. 4th Int'l. Symp. on Pers., Indoor, and Mobile Radio Commun. (PIMRC '93)*, Yokohama, Japan, Oct. 1993, pp. 292-96.
- [53] U. Mitra and H. V. Poor, "Analysis of an Adaptive Decorrelating Detector for Synchronous CDMA Channels," *IEEE Trans. Commun.*, vol. 44, no. 2, Feb. 1996, pp. 257-68.
- [54] S. Moshavi, E. G. Kanterakis, and D. L. Schilling, "Multistage Linear Receivers for DS-CDMA Systems," *Int'l. J. Wireless Info. Networks*, vol. 3, no. 1, Jan. 1996. (patent pending).
- [55] S. Moshavi, "Multistage Linear Detectors for DS-CDMA Communications," Ph.D. dissertation, Dept. Elec. Eng., City Univ. New York, NY, Jan. 1996. (patents pending)
- [56] H. Y. Wu and A. Duel-Hallen, "Performance Comparison of Multi-User Detectors with Channel Estimation for Flat Rayleigh Fading CDMA Channels," *Wireless Pers. Commun.*, July/Aug. 1996.
- [57] S. D. Gray, M. Kocic, and D. Brady, "Multi-User Detection in Mismatched Multiple-Access Channels," *IEEE Trans. Commun.*, vol. 43, no. 12, Dec. 1995, pp. 3080-89.
- [58] R. Kohno, "Spatial and Temporal Filtering for Co-Channel Interference in CDMA," *Code Division Multiple Access Communications*, S. G. Glisic and P. A. Leppanen, eds., The Netherlands: Kluwer, 1995, pp. 117-46.
- [59] J. M. Holtzman, "DS/CDMA Successive Interference Cancellation," *Proc. IEEE Int'l. Symp. on Spread Spectrum Techniques and Appl. 1994 (ISSSTA '94)*, Oulu, Finland, July 1994, pp. 69-78.
- [60] A. J. Viterbi, "Very Low Rate Convolutional Codes for Maximum Theoretical Performance of Spread-Spectrum Multiple-Access Channels," *IEEE JSAC*, vol. 8, no. 4, May 1990, pp. 641-49.
- [61] A. D. Wyner, "Recent Results in the Shannon Theory," *IEEE Trans. Info. Theory*, vol. IT-20, Jan. 1974, pp. 2-10.
- [62] T. M. Cover, "Some Advances in Broadcast Channels," *Advances in Communication Systems*, A. J. Viterbi, ed., New York: Academic, 1975, pp. 229-60.
- [63] A. B. Carleial, "A Case Where Interference Does Not Reduce Capacity," *IEEE Trans. Info. Theory*, vol. IT-21, Sept. 1975, pp. 569-70.
- [64] I. Seskar, "Practical Implementation of Successive Interference Cancellation," presentation, WINLAB Semi-Annual Res. Rev., Rutgers Univ., NJ, Apr. 26, 1996.
- [65] P. Patel and J. Holtzman, "Analysis of a Simple Successive Interference Cancellation Scheme in a DS/CDMA System," *IEEE JSAC*, vol. 12, no. 5, June 1994, pp. 796-807.
- [66] M. Ewerbring, B. Gudmundson, G. Larsson, and P. Teder, "CDMA with Interference Cancellation: A Technique for High Capacity Wireless Systems," *Proc. ICC '93*, Geneva, Switzerland, 1993, pp. 1901-6.
- [67] M. K. Varanasi and B. Aazhang, "Multistage Detection in Asynchronous Code-Division Multiple-Access Communications," *IEEE Trans. Commun.*, vol. 38, no. 4, Apr. 1990, pp. 509-19.
- [68] R. Kohno et al., "Combination of an Adaptive Array Antenna and a Canceller of Interference for Direct-Sequence Spread-Spectrum Multiple-Access System," *IEEE JSAC*, vol. 8, no. 4, May 1990, pp. 675-82.
- [69] R. Kohno et al., "An Adaptive Canceller of Cochannel Interference for Spread-Spectrum Multiple-Access Communication Networks in a Power

Line," *IEEE JSAC*, vol. 8, no. 4, May 1990, pp. 691-99.

[70] M. K. Varanasi and B. Aazhang, "Near-Optimum Detection in Synchronous Code-Division Multiple-Access Systems," *IEEE Trans. Commun.*, vol. 39, no. 5, May 1991, pp. 725-36.

[71] U. Fawer and B. Aazhang, "A Multi-User Receiver for Code Division Multiple Access Communications over Multipath Channels," *IEEE Trans. Commun.*, vol. 43, no. 2/3/4, Feb./Mar./Apr. 1995, pp. 1556-65.

[72] P. Patel and J. Holtzman, "Performance Comparison of a DS/CDMA System Using a Successive Interference Cancellation (IC) Scheme and a Parallel IC Scheme under Fading," *Proc. ICC '94*, New Orleans, LA, May 1994, pp. 510-14.

[73] B. Zhu, N. Ansari, and Z. Siveski, "Convergence and Stability Analysis of a Synchronous Adaptive CDMA Receiver," *IEEE Trans. Commun.*, vol. 43, no. 12, Dec. 1995, pp. 3073-79.

[74] T. R. Giallorenzi and S. G. Wilson, "Decision Feedback Multi-User Receivers for Asynchronous CDMA Systems," *Proc. IEEE Globecom '93*, Houston, TX, Dec. 1993, pp. 1677-82.

[75] B. S. Abrams, A. E. Zeger, and T. E. Jones, "Efficiently Structured CDMA Receiver with Near-Far Immunity," *IEEE Trans. Vehic. Tech.*, vol. 44, no. 1, Feb. 1995, pp. 1-13.

[76] D. Divsalar and M. Simon, "Improved CDMA Performance Using Parallel Interference Cancellation," JPL pub. 95-21, Oct. 1995 (patent pending).

[77] A. Duel-Hallen, "Decorrelating Decision-Feedback Multi-User Detector for Synchronous Code-Division Multiple Access Channel," *IEEE Trans. Commun.*, vol. 41, no. 2, Feb. 1993, pp. 285-90.

[78] A. Duel-Hallen, "A Family of Multi-User Decision-Feedback Detectors for Asynchronous Code-Division Multiple Access Channels," *IEEE Trans. Commun.*, vol. 43, no. 2/3/4, Feb./Mar./Apr. 1995, pp. 421-34.

[79] A. Klein, G. K. Kaleb, and P. W. Baier, "Zero Forcing and Minimum Mean-Square-Error Equalization for Multi-User Detection in Code-Division Multiple-Access Channels," *IEEE Trans. Vehic. Tech.*, vol. 45, no. 2, May 1996, pp. 276-87.

[80] G. K. Kaleb, "Channel Equalization for Block Transmission Systems," *IEEE JSAC*, vol. 13, no. 1, Jan. 1995, pp. 110-21.

[81] P. Jung and J. Blanz, "Joint Detection with Coherent Receiver Antenna Diversity in CDMA Mobile Radio Systems," *IEEE Trans. Vehic. Tech.*, vol. 44, no. 1, Feb. 1995, pp. 76-88.

[82] L. Wei and C. Schlegel, "Synchronous DS-SSMA System with Improved Decorrelating Decision Feedback Multi-User Detection," *IEEE Trans. Vehic. Tech.*, vol. 43, no. 3, Aug. 1994, pp. 767-72.

[83] G. W. Stewart, *Introduction to Matrix Computations*, New York: Academic, 1973.

[84] M. Honig, U. Madhow, and S. Verdú, "Blind Adaptive Multiuser Detection," *IEEE Trans. Info. Theory*, vol. 41, no. 4, July 1995, pp. 944-60.

[85] U. Madhow and M. L. Honig, "MMSE Interference Suppression for Direct Sequence Spread-Spectrum CDMA," *IEEE Trans. Commun.* vol. 42, no. 12, Dec. 1994, pp. 3178-88.

[86] R. M. Buehrer and B. D. Woerner, "Analysis of Adaptive Multistage Interference Cancellation for CDMA Using an Improved Gaussian Approximation," *Proc. IEEE MILCOM '95*, San Diego, CA, Nov. 1995, pp. 1195-99.

[87] A. J. Viterbi, *CDMA: Principles of Spread Spectrum Communication*, Reading, MA: Addison-Wesley, 1995.

[88] H. Taub and D. L. Schilling, *Principles of Communication Systems*, 2nd ed., New York: McGraw-Hill, 1986.

#### ENDNOTES

- 1 These properties include: frequency reuse of one, resistance to multipath fading, multipath diversity combining (RAKE reception), soft capacity, soft handoff, natural usage of the voice activity cycle (VAC), ability to overlay on existing systems, ability to use forward error correction coding without overhead penalty, natural exploitation of sectored antennas and adaptive beamforming, ease of frequency management, low probability of detection and intercept (LPD and LPI), and jam resistance. See [1-4] for details.
- 2 Note that we focus here only on the effect of MAI, and not on the effect of narrowband (NB) interference. A good survey of work dealing with CDMA in the presence of NB interference can be found in [6]. See also [7] where multiuser detection is proposed for eliminating NB interference.
- 3 The detector would consist of a bank of  $K$  matched filters, where each filter is "matched" to a different code waveform. Matched filter detection and correlation detection are equivalent methods of implementing optimal detection where the only interference is from additive white Gaussian noise [8], that is, in a single-user channel.
- 4 The operation of the conventional detector can also be explained in the frequency domain. All signals arrive at the receiver spread in frequency by the processing gain factor,  $PG$ . This has the effect of reducing the power of each signal over any given narrow band of frequencies. After multiplying the received signal by the code of user  $k$ , the signal of user  $k$  is de-spread back to the original information bandwidth; the other signals, however, remain spread in frequency (i.e.,  $g_k(t)g_k(t)$  is equivalent to some new spreading code waveform). The integrator then acts as a low pass filter with cut-off at frequencies  $\pm f_b$ . Within this frequen-

- cy range the de-spread signal is at full power, while the power of the interfering signals has been reduced by an amount proportional to the processing gain [8].
- 5 A popular approximation of the SNR at the output of the conventional detector is obtained by modeling the MAI as a Gaussian random variable [9]. Thus, for the conventional detector, the MAI can be lumped with the thermal noise for analysis, that is, it raises the noise floor. The resulting equation yields fairly accurate probability of error results for most reasonable system parameters (i.e., for  $K$ ,  $PG$ , and probability of error not too small [10]). This equation is often used in analysis of DS-CDMA systems, e.g., [3, 4].
  - 6 Another important area of research is the design of improved single-user detectors, where the code of only one (desired) user is known. Here detection is optimized in some way for the multi-user channel, where the general structure of the interference is known to be that of other direct-sequence users. As a substitute for the specific knowledge of the interfering users' code waveforms, these detectors generally rely heavily on adaptive signal processing. They are also sometimes referred to as adaptive multi-user detectors. An overview of the work in this area can be found in [15].
  - 7 Issues dealt with include multipath, fading, noncoherent detection, general modulation schemes, power variation and power control, coding, acquisition and tracking (code synchronization), channel estimation, multiple and adaptive antennas, complexity and cost, efficient suboptimal implementations, application to IS-95, and sensitivity and robustness (e.g., the effects of amplitude and phase estimation errors, delay tracking errors, and quantization errors).
  - 8 Multipath is an important issue in multi-user detection. The bandwidth of a DS-CDMA signal is very wide (or equivalently, the chip duration is very small); hence more than one signal path can generally be resolved at the receiver [8]. This yields what is known as "multipath diversity." The conventional detector in this case takes the form of a bank of RAKE detectors [8], which allows it to take advantage of the available diversity. The RAKE detector of each user has  $M$  "fingers," where each finger detects a different signal path through a matched filter. The RAKE receiver then combines the  $M$  outputs in some manner (e.g., maximal ratio or equal gain). The name "RAKE" comes from a similarity of this detector to an ordinary garden rake [8]. There has been much literature on multi-user detection in a multipath environment, e.g., [19-23] (for the decorrelating detector), [24, 25] (for the PIC detector), and [26, 27] (for the MLS detector and the decorrelating detector in a 2 path Rician fading channel). See [16-18] for additional references and discussion. One approach to multi-user detection in the presence of multipath is to maximal ratio combine the  $M$  corresponding signal paths for each user and then perform multi-user detection on the resulting  $K$  signals. A more common approach is to treat each path as a separate user with respect to the multi-user detection algorithm. Thus, first multi-user detection is performed on  $MK$  signals and then RAKE combining takes place on the corresponding  $M$  outputs for each user.
  - 9 We are assuming BPSK modulation and thus coherent detection. However, in the IS-95 standard, a pilot signal is not available on the uplink (it is available, however, in IS-665). Thus, a coherent reference is not available for tracking the phase, and noncoherent detection is necessary [5]. Two basic works that consider noncoherent multi-user detection (for the decorrelating detector) are [28] for the synchronous channel and [29] for the asynchronous channel; other articles include [19, 21-23, 30] (for the decorrelating detector), and [65] (for the SIC detector). See [16-18] for additional references and discussion.
  - 10 The ability to detect signals from multiple cells is already assumed in IS-95 for the implementation of soft-handoff [1]. Here base stations of neighboring cells may simultaneously transmit to, and receive from the same mobile user. Note that the value of 0.55 given for the spillover ratio in [1] actually already includes soft handoff users [87].
  - 11 By definition, the maximum-likelihood sequence detector chooses  $\mathbf{d}$  to maximize  $P(r(t)|\mathbf{d})$ ; but if all  $\mathbf{d}$  vectors are equally probable, this is equivalent to maximizing  $P(\mathbf{d}|r(t))$  [8]. Thus, the MLS detector yields the most likely transmitted  $\mathbf{d}$  vector as long as all possible  $\mathbf{d}$  vectors are equally likely [8]. It can be shown that maximizing the probability  $P(r(t)|\mathbf{d})$  is equivalent to maximizing the log likelihood function  $\mathcal{L} = 2\mathbf{d}^T \mathbf{A} \mathbf{y} - \mathbf{d}^T \mathbf{A} \mathbf{R} \mathbf{A} \mathbf{d}$  where  $\mathbf{d} \in \{-1, 1\}^{MK}$  [41]. From this follows the well known result that  $\mathbf{y}$  (the matched filter output over the whole message) is a sufficient statistic for optimum detection of the transmitted data [31].
  - 12 MLS detection guarantees the most likely sequence (i.e. a global optimum). An alternate optimality criteria is "minimum probability of error," which results from the maximization of the marginal a posteriori distributions,  $P(d_{k,i}|r(t))$ ,  $k = 1 \dots K$ ,  $i = 1 \dots N$  (locally optimum) [31]. This is more difficult to implement. Fortunately, the bit error rate of the MLS detector turns out to be indistinguishable from the minimum probability of error for SNR regions of interest, that is, where the thermal noise is not dominant [16]; in the limit as the noise goes to zero, the MLS error rate is equivalent to that of the minimum error rate. A 2 user synchronous channel example which illustrates the difference between the MLS criteria and the minimum probability of error criteria is given in [16], and repeated here. Assume that the joint posterior

- probabilities  $P\{d_1, d_2|r(t)\}$ , are given as  $P\{1, 1|r(t)\} = 0.26$ ,  $P\{-1, 1|r(t)\} = 0.26$ ,  $P\{1, -1|r(t)\} = 0.27$ , and  $P\{-1, -1|r(t)\} = 0.21$ . The most likely sequence is  $\{1, -1\}$ ; however, the most likely value of the second user's bit is 1.
- 13 Besides yielding the most likely transmitted sequence, this detector is also optimal in terms of the performance measures known as the asymptotic efficiency and the near-far resistance [31, 40, 41]. These metrics are covered in the surveys [16, 18].
  - 14 In [31] a Viterbi implementation is proposed with path metrics that are a function of the user crosscorrelations, and that are similar to that of a single-user periodic time varying ISI channel with memory  $K - 1$ ; the resulting Viterbi algorithm has  $2^K - 1$  states and a complexity per binary decision on the order of  $2^K$ . Unfortunately, no algorithm is known to solve the maximization of the likelihood function  $\mathcal{L}$  (see Endnote 11) in polynomial time in  $K$  (i.e., it is NP-hard) [31]. An illustrative example of MLS detection for an asynchronous 2 user DS-CDMA system is spelled out in [16]. Note that [58] cites two articles by Kohno from 1982 and 1983 that also propose a Viterbi algorithm implementation with a complexity per binary decision on the order of  $2^K$ ; both of these articles appear only in Japanese. Viterbi implementations of higher complexity were also proposed in [32, 38].
  - 15 A natural simplification of MLS detection is to replace the Viterbi algorithm with a sequential decoder, as is done for convolutional decoding [33]. Sequential decoding searches for the most likely path based on local metric values; in contrast, the Viterbi algorithm tracks and evaluates all possible paths. Although simpler, sequential decoding for DS-CDMA is still fairly difficult to implement.
  - 16 As is discussed below, the decorrelating detector pays a noise enhancement penalty for eliminating the MAI. Thus, if the MAI is relatively low and the background noise power is relatively high, ignoring the MAI, as does the conventional detector, may yield better performance [16, 40].
  - 17 In brief, the near-far resistance [31, 40, 41] is a performance measure that indicates performance under worst-case conditions of interfering powers; it provides some quantification of the resistance of a detector's error performance to the power of the interfering users. A detector that is near-far resistant (i.e., the metric is not equal to zero), can achieve any given performance level in the multi-user environment, no matter how powerful the multi-user interference, provided that the desired user is supplied enough power. Both the maximum likelihood sequence detector and the decorrelating detector are guaranteed to be near-far resistant for linearly independent users (linearly dependent users, however, are not near-far resistant). Both detectors also yield the largest value of this metric for a given set of code waveforms. In contrast, the conventional detector is not near-far resistant, unless all waveforms are orthogonal. For more details on near-far resistance, see [16].
  - 18 Two recent papers treat the decorrelating detector as a special case of what is termed "parallel group detectors" [42, 43]. These detectors bridge the gap in performance and complexity between the decorrelating detector, (which corresponds to the case of one user per group), and the MLS detector (which corresponds to the case of all users in one group).
  - 19 As mentioned above, the decorrelating detector is the optimal sequence detector (linear or nonlinear) when the energies of the users are unknown. If they are known, however, there are linear detectors that provide better probability of error performance. This involves trading off some MAI reduction for less noise enhancement. An example of this is the MMSE detector discussed in the next subsection.
  - 20 Degradation from the ideal decorrelating detector performance results because of the "edge effects" [45, 46]. Some proposals include a form of "edge correction" to mitigate this problem [45, 46]; other proposals involve physically separating the data sub-blocks, to entirely avoid the edge problem [47, 48, 79, 81]. The latter scheme, however, requires some time synchronization among users.
  - 21 It is shown in [40] that for the case of short codes (codes that repeat each bit), and where the message length,  $N$ , approaches infinity, the decorrelating detector approaches a  $K$ -input  $K$ -output linear time-invariant noncausal infinite memory-length filter. It is further shown in [40] that under mild conditions a stable unique realization of this filter exists. Since the filter has infinite memory-length and is non-causal, a practical implementation would require truncation to a finite length filter, and the insertion of sufficient delay. Since stability requires that the impulse response,  $h(n)$ , go to zero as  $n \rightarrow \infty$ , the more remote symbols will count less heavily. Therefore, the approximation to the exact decorrelating filter will be good for a truncation window (filter memory) of sufficient length [40].
  - 22 See also [50] where an adaptive decorrelating detector is proposed that avoids the need for computations with the correlation matrix.
  - 23 On the other hand, as the noise gets very large, or the MAI amplitudes get very small,  $L_{MMSE} = (2/N_0)A^2$ . In this case, performance of the MMSE detector approaches that of the conventional detector [15, 45]. See Endnote 16.
  - 24 For example, in [45] MMSE detection takes place on blocks of subsequences; in [85] "one-shot" MMSE detection is proposed, where detection is based only on observation over one transmission interval. MMSE detection has also received much attention lately because of its ability to be implemented adaptively, where the codes of the interfering users are not known, that is, improved single-user detection (e.g. [84, 85]). For more on this subject, see [15].
  - 25 In this case, the PE detector structure can be thought of as being a  $K$ -input  $K$ -output linear infinite memory-length filter realization of the decorrelating detector.
  - 26 Note that soft-decision subtractive interference cancellation detectors can usually also mathematically be classified as linear detectors.
  - 27 The Wireless Information Network Laboratory (WINLAB) at Rutgers University, New Jersey, is currently implementing a prototype of the SIC detector which utilizes soft decisions [64]. A soft-decision SIC detector was initially investigated in [65].
  - 28 A distinctly different SIC scheme that does cancellation in the Walsh-Hadamard spectral domain is discussed in [66]. Additional references on this approach can be found in [18].
  - 29 Because of the cancellation order, this detector is most potent when there is significant power variation between each users' received signal. A specific geometric power distribution is derived in [60] that enables each user to see the same level of signal power to interference (+ noise) ratio, and produce the same probability of error. It is also shown in [60] that by using the SIC detector with this power profile, along with very low rate forward error correction (FEC) codes, it is possible for the composite bit rate of all users to approach the Shannon limit.
  - 30 The multistage PIC algorithm is used in [71] as part of a joint parameter estimation and data detection scheme.
  - 31 This detector can be considered to be a special case of the modified parallel group detectors introduced in [42] (corresponding to the case of one user per group).
  - 32 An adaptive version of this detector that does not require explicit estimation of the received amplitudes is proposed in [73] for synchronous systems.
  - 33 In [75] a PIC detector is proposed that is based entirely on feedback cancellation: the outputs of the correlators are continuously fed back during the correlation for cancellation.
  - 34 Note that the cancellation takes place on the post correlation MAI terms. Although both the SIC and PIC detectors were described earlier with "pre-correlation" cancellation, they too can be equivalently implemented through "post-correlation" cancellation [24, 59, 65].
  - 35 The ZF-DF detector can be considered to be a special case of the "sequential group detectors" introduced in [42] (corresponding to the case of one user per group). A general analysis is given there without the assumption that all past decisions are correct.
  - 36 An MMSE-DF detector is proposed in [78, 79, 81] which is analogous to the MMSE-DF equalizer [8]. Here the feed-forward and feedback filters are chosen to minimize the mean square error under the assumption that all past decisions are correct. This detector is similar to the ZF-DF detector except that the feed-forward filter is obtained by Cholesky factoring the matrix  $\{ARA + (N_0/2)I\}$ . Like in equalization, the MMSE-DF detector outperforms the ZF-DF detector.
  - 37 An improved ZF-DF detector is proposed for synchronous channels in [82] which feeds back more than one set of likely decision vectors along with their corresponding metrics. The approach of this detector is similar to that of sequential decoding.
  - 38 The "Schur algorithm" with parallel processing is proposed for Cholesky factorization in [80]; it results in a complexity that is linear with the order of the matrix.

## BIOGRAPHY

Shimon Moshavi [S '91] received the B.A. degree in physics from Yeshiva University in 1988, the M.S. degree in electrical engineering from City College of New York in 1994, and the Ph.D. degree in electrical engineering from City University of New York in January 1996. Since January 1996 he has been a research scientist at Bell Communications Research (Bellcore) in Red Bank, New Jersey, in the Wireless Systems Research Department (Tel: 908-758-5091, moshavi@bellcore.com). His current interests include communication theory, CDMA, multi-user detection, and wireless networks.